

## μC/USB Device™ Universal Serial Bus Device Stack

### DESCRIPTION

μC/USB Device is a USB device stack designed for embedded systems equipped with a USB device controller. A hardware abstraction layer makes it easy to port μC/USB-Device by simply modifying existing hardware access routines. Drivers for several common device classes (Mass Storage, CDC, HID) are offered, supplemented by a framework to easily develop new class drivers. The stack runs with or without an RTOS.

μC/USB Device uses a modular architecture with three software layers between the application and the hardware.

- Each target requires a *Device Controller Driver* to interface with the device controller hardware to process interrupts, notify the stack core of bus events, and receive and transmit packets.
- The *Device core* controls packet reception and transmission and responds to standard host requests during enumeration (the process by which a host discovers the feature of a device).
- The target provides its functionality to the host with one or more *class drivers* (e.g. the Mass Storage Class driver). Each class driver responds to class-specific requests and may provide an API for controlling the feature or receiving and transmitting information.

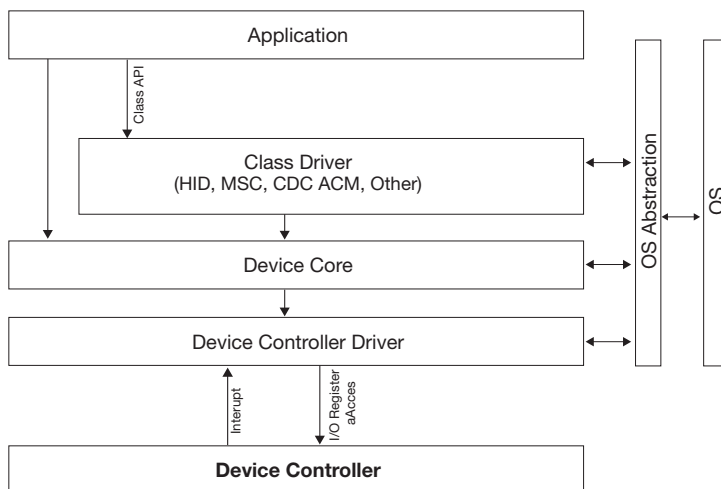

### FEATURES

- **Speed** – Supports full-speed (12 Mbit/sec) and high speed (480 Mbit/sec) controllers. The highest achievable transfer rate is approximately 1.1 MByte/sec on a fast system (ARM7). Better transfer rates are available with high-speed controllers, yet most platforms do not reach theoretical maximum (approximately 50 Mbytes/sec). A high-speed controller should provide an order-of-magnitude performance increase over a full-speed controller on a comparable MCU/MPU.
- **Memory Footprint** – μC/USB-Device’s footprint can be scaled to contain only the features required for the application at hand.
- **Real-Time Kernel Support** – μC/USB-Device can be used with or without a Real-Time Kernel.
- **Start/Test Application** - Simple target test applications are provided for all USB device classes, in all significant configurations. For bulk, mass storage, and HID classes, simple Windows applications are included, constituting an end-to-end demonstration of USB functionality.

μC/USB Device

Who should use this stack?	Manufacturer who wants to build a USB peripheral rapidly and easily.
Other related Micrium’s products?	μC/OS-II, μC/OS-III
Source code	ANSI-C
Real-time kernel	With or without
Specification compliance	USB 1.1 and USB 2.0
Supported transfer types	Bulk, Control, Interrupt, Isochronous
Respond to USB standard request	Yes
Supported devices classes	Mass Storage, HID, CDC ACM, Vendor-specific (with Bulk transfer)
HID demo	Mouse, keyboard
MSC demo	PC Host can write/read data to/from USB device
CDC ACM demo	PC Host interacts with the USB device recognized as a virtual COM port.

# Micrium

## µC/USB Host™ Universal Serial Bus Device Stack

### CLASS SUPPORT

The Mass Storage Class (MSC) driver enables the use of the embedded target device as a USB mass storage device. Typical applications include digital cameras, USB stick, MP3 player, DVD player, and any target with a USB interface.

The Human Interface Device (HID) Class driver allows the target to use a standard USB class (without a special host driver) for a vendor-specific communication protocol.

The Communications Device Class (CDC) encompasses several communication models. The *Abstract Control Model (ACM)* converts the USB device into a serial communication device. The target is recognized by the host as a serial interface (USB2COM, virtual COM port). Typical applications include modems, telephone systems and fax machines.

The Bulk driver allows the device to use bulk transfer to exchange data with the host. This driver can be used to develop a vendor-specific class based on bulk transfers. Unlike the HID class, a special host driver is required, as Windows does not natively support this type of device. A Windows driver is provided as an executable (\*.sys), although it is also available as source code.

### DEVICE CONTROLLER DRIVER

µC/USB-Device features a hardware abstraction layer allowing rapid addition of support for the new devices. The provided device drivers are tested with the *USB Command Verifier (USBCV) v1.3.2*. USBCV is the official compliance test tool, which evaluates high, full and low-speed USB devices for conformance to the USB Device Framework (Chapter 9), Hub device class (Chapter 11), HID class, MSC class and OTG specifications. The tool is provided by the USB Implementers Forum.

Micrium's documentation provides all of the information required for driver development, or contact Micrium for a quote.

### MEMORY FOOTPRINT

This footprint has been obtained with:

- IAR v5.20 ARM compiler toolchain for the core ARM7TDMI-S using the ARM mode.
- Compiler: high optimization with the balanced option for size and speed.
- Device controller: LPC2468

Layer	Code (kB)	Constant (kB)	Data (kB)
OS abstraction	0.78	-	-
Device Core	7.20	0.05	0.55
Device Controller driver	3.10	-	0.26
TOTAL (kB)	11.08	0.05	0.81

Legend

µC/USB-Host

Layer	Code (kB)	Constant (kB)	Data (kB)
Bulk driver	0.80	0.06	0.30
CDC ACM Class driver	2.72	0.15	1.11
HID Class driver	1.64	0.07	0.31
MSC Class driver	4.91	0.08	2.80

For pricing, delivery, and ordering information, please contact Micrium at (sales number), or visit Micrium's website at: [www.micrium.com](http://www.micrium.com).

# Micrium

For the way Engineers work